

VALVOLA A SFERA  
BALL VALVE

Art. 07432

VALVOLA A SFERA A INTERRARE IN ACCIAIO, PN20, PASSAGGIO TOTALE, PER GAS NATURALE, ESTREMITA' A SALDARE CON PROLUNGA E QUADRO DI MANOVRA

FULLY WELDED BODY FULL BORE FLOATING BALL VALVE, PN 20, FOR NATURAL GAS, ELONGATED STEM FOR INSTALLATION UNDERGROUND LEVEL, BW ENDS WITH SQUARE FOR MANUAL OPERATOR CONNECTOR

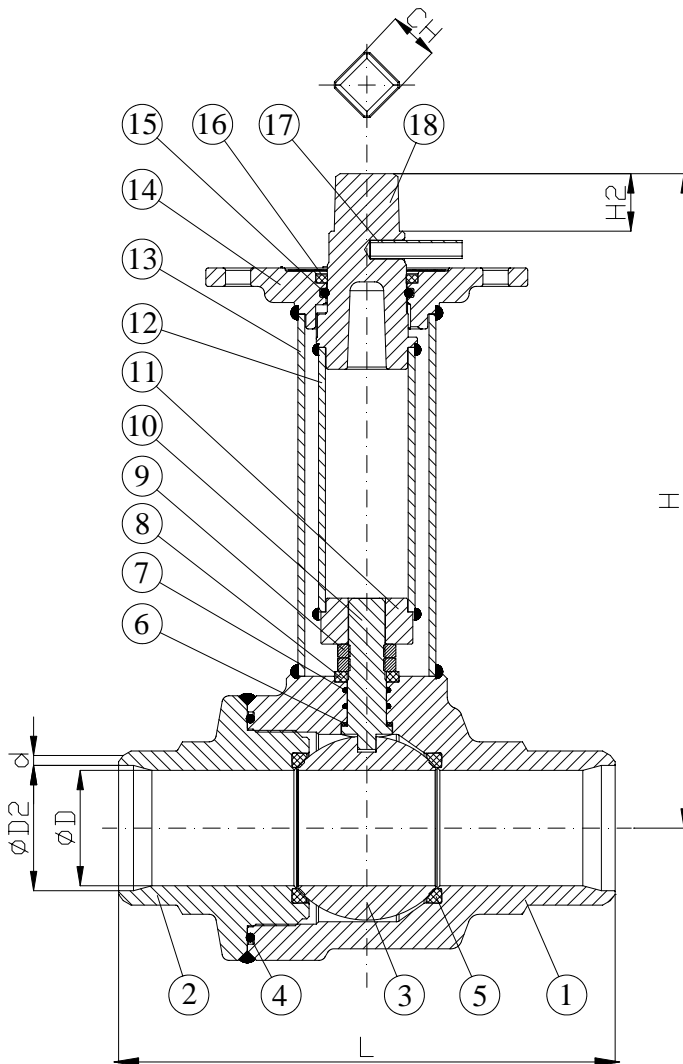

**NORMA PROGETTO:** UNI 9734  
**TEMPERATURA ESER:** da -20° a +120°C  
**DESIGN STANDARD:** UNI 9734  
**WORKING TEMP:** from -20° to +120°C

DENOMINAZIONE PART	MATERIALI MATERIALS
1 CORPO BODY	ACCIAIO A216-WCB STEEL A216-WCB
2 MANICOTTO END CONNECTION	ACCIAIO ASTM-A105 STEEL ASTM-A105
3 SFERA BALL	ACCIAIO INOX A182-F304 STAINLESS STEEL A182-F304
4 O-RING O-RING	NBR NBR
5 GUARNIZIONE SFERA BALL SEAT	PTFE VERGINE VIRGIN PTFE
6 RONDELLA STEM GASKET	PTFE PTFE
7 O-RING O-RING	VITON VITON
8 BUSSOLA PACKING GLAND	POM POM
9 DADO NUT	ACCIAIO AL CARBONIO CARBON STEEL
10 ALBERO STEM	ACCIAIO INOX A182-F304 STAINLESS STEEL A182-F304
11 RINVIO ASTA STEM TRASMISSION	ACCIAIO ASTM-A105 STEEL ASTM-A105
12 PROLUNGA INTERNA STEM EXTENSION	ACCIAIO AL CARBONIO CARBON STEEL
13 PROLUNGA ESTERNA STEM EXTENSION	ACCIAIO AL CARBONIO CARBON STEEL
14 TAPPO CAP	ACCIAIO A216-WCB STEEL A216-WCB
15 O-RING O-RING	VITON VITON
16 GUARNIZIONE SEAT	PTFE VERGINE VIRGIN PTFE
17 INDICATORE POSIZIONE POSITION INDICATOR	ACCIAIO AL CARBONIO CARBON STEEL
18 QUADRO MANOVRA OPERATION SQUARE	ACCIAIO A216-WCB STEEL A216-WCB

DN	Inch.	D	D2	d	L	H	H2	CH	Peso (kg) Weight
25	1	25	26.64	3.38	165	600	25	22x22	9.7
32	1 1/4	30	35.08	3.56	191	600	25	22x22	10.3
40	1 1/2	38	43.1	3.9	191	600	25	22x22	14
50	2	50	54.5	4.3	216	600	25	22x22	17
65	2 1/2	64	62.68	5.16	241	600	25	22x22	25
80	3	76	83.1	4.3	283	600	25	22x22	33
100	4	95	107.9	4.8	305	600	25	22x22	40
125	5	125	132.3	5.5	380	600	25	22x22	55

**RIVESTIMENTO:** Vernice di colore nero RAL 9005 con spessore min 100µm.

**SURFACE PROTECTION:** black paint color RAL 9005 and minimum thickness of 100µm.

VALVOLA A SFERA

BALL VALVE

Art. 07432

VALVOLA A SFERA A INTERRARE IN ACCIAIO, PN20, PASSAGGIO TOTALE, PER GAS NATURALE, ESTREMITA' A SALDARE CON PROLUNGA E QUADRO DI MANOVRA

FULLY WELDED BODY FULL BORE FLOATING BALL VALVE, PN 20, FOR NATURAL GAS, ELONGATED STEM FOR INSTALLATION UNDERGROUND LEVEL, BW ENDS WITH SQUARE FOR MANUAL OPERATOR CONNECTOR

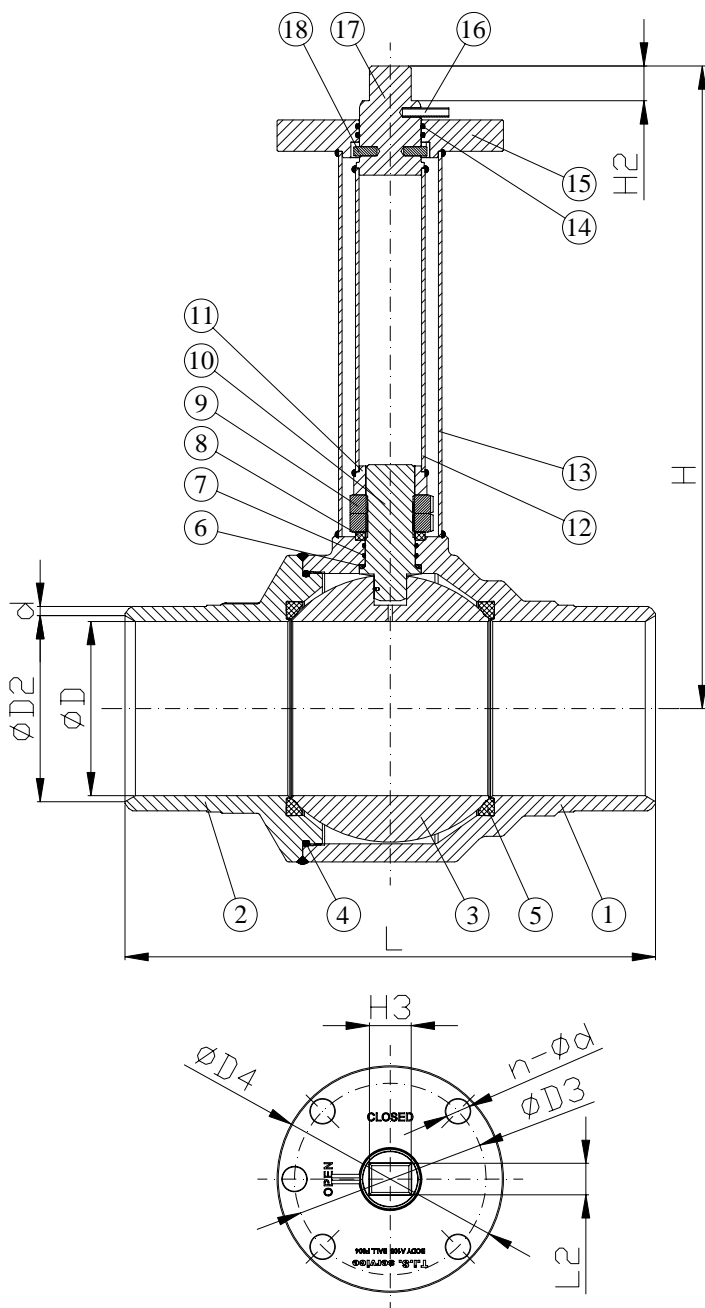

NORMA PROGETTO: UNI 9734  
TEMPERATURA ESER: da -20° a +120°C

DESIGN STANDARD: UNI 9734  
WORKING TEMP: from -20° to +120°C

DENOMINAZIONE PART	MATERIALI MATERIALS
1 CORPO BODY	ACCIAIO A216-WCB STEEL A216-WCB
2 MANICOTTO END CONNECTION	ACCIAIO A216-WCB STEEL A216-WCB
3 SFERA BALL	ACCIAIO INOX A182-F304 STAINLESS STEEL A182-F304
4 O-RING O-RING	NBR NBR
5 GUARNIZIONE SFERA BALL SEAT	PTFE PTFE
6 RONDELLA STEM GASKET	PTFE PTFE
7 O-RING O-RING	VITON VITON
8 BUSSOLA PACKING GLAND	POM POM
9 DADO NUT	ACCIAIO AL CARBONIO CARBON STEEL
10 ALBERO STEM	ACCIAIO INOX A182-F304 STAINLESS STEEL A182-F304
11 RINVIO ASTA STEM TRASMISSION	ACCIAIO ASTM-A105 STEEL ASTM-A105
12 PROLUNGA INTERNA STEM EXTENSION	ACCIAIO AL CARBONIO CARBON STEEL
13 PROLUNGA ESTERNA STEM EXTENSION	ACCIAIO AL CARBONIO CARBON STEEL
14 O-RING O-RING	VITON VITON
15 TAPPO CAP	ACCIAIO ASTM-A105 STEEL ASTM-A105
16 SPINA ELASTICA ELASTIC PIN	ACCIAIO AL CARBONIO CARBON STEEL
17 QUADRO MANOVRA OPERATION SQUARE	ACCIAIO AVP AVP STEEL
18 SPINA CILINDRICA CYLINDRICAL PIN	ACCIAIO INOX STAINLESS STEEL

RIVESTIMENTO: Vernice di colore nero RAL 9005 con spessore min 100µm.

SURFACE PROTECTION: black paint color RAL 9005 and minimum thickness of 100µm.

DN	Inch.	D	D2	D3	D4	d	n-ød	L	L2	H	H2	H3	Peso (kg) Weight
150	6	150	160.3	165	195	6	4-ø21	457	27	600	30	36	75

VALVOLA A SFERA  
BALL VALVE

Art. 07432

VALVOLA A SFERA A INTERRARE IN ACCIAIO, PN20, PASSAGGIO TOTALE, PER GAS NATURALE, ESTREMITA' A SALDARE CON PROLUNGA E QUADRO DI MANOVRA

FULLY WELDED BODY FULL BORE FLOATING BALL VALVE, PN 20, FOR NATURAL GAS, ELONGATED STEM FOR INSTALLATION UNDERGROUND LEVEL, BW ENDS WITH SQUARE FOR MANUAL OPERATOR CONNECTOR

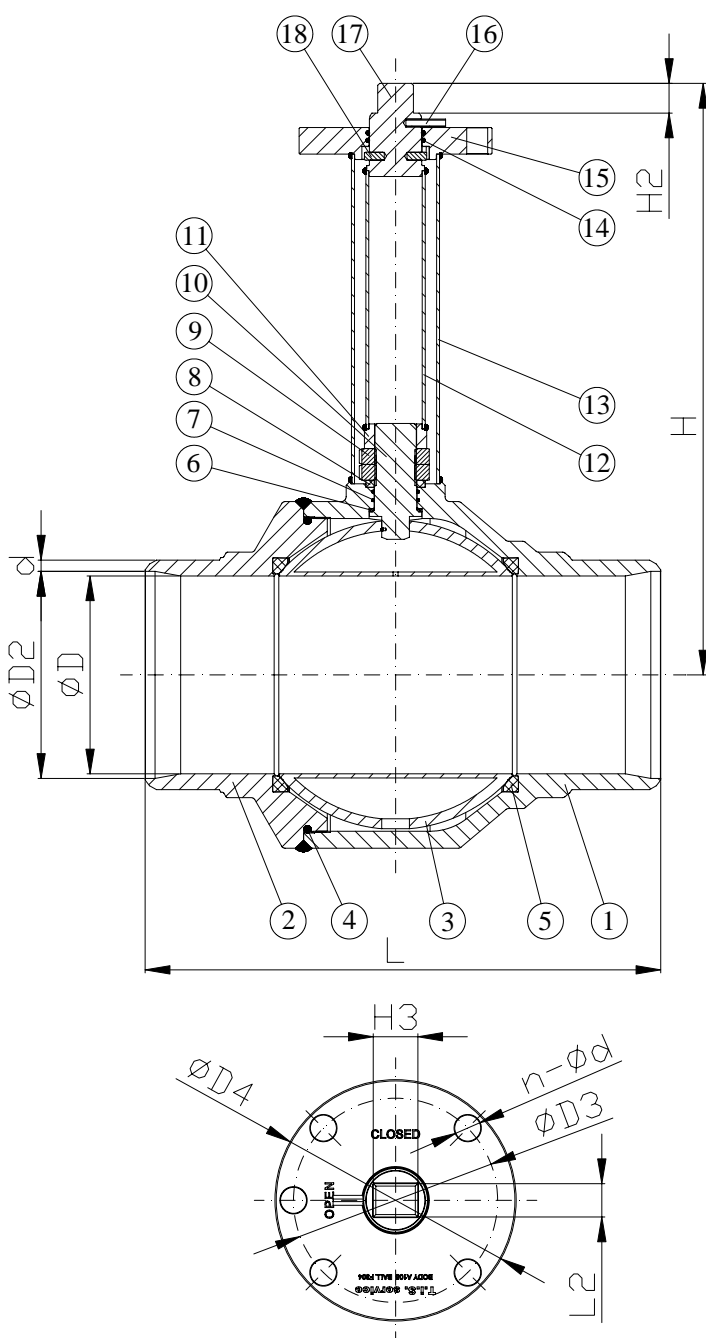

**NORMA PROGETTO:** UNI 9734  
**TEMPERATURA ESER:** da -20° a +120°C  
**DESIGN STANDARD:** UNI 9734  
**WORKING TEMP:** from -20° to +120°C

DENOMINAZIONE PART	MATERIALI MATERIALS
1 CORPO BODY	ACCIAIO A216-WCB STEEL A216-WCB
2 MANICOTTO END CONNECTION	ACCIAIO A216-WCB STEEL A216-WCB
3 SFERA BALL	ACCIAIO INOX A182-F304 STAINLESS STEEL A182-F304
4 O-RING O-RING	NBR NBR
5 GUARNIZIONE SFERA BALL SEAT	PTFE PTFE
6 RONDELLA STEM GASKET	PTFE PTFE
7 O-RING O-RING	VITON VITON
8 BUSSOLA PACKING GLAND	POM POM
9 DADO NUT	ACCIAIO AL CARBONIO CARBON STEEL
10 ALBERO STEM	ACCIAIO INOX A182-F304 STAINLESS STEEL A182-F304
11 RINVIO ASTA STEM TRASMISSION	ACCIAIO ASTM-A105 STEEL ASTM-A105
12 PROLUNGA INTERNA STEM EXTENSION	ACCIAIO AL CARBONIO CARBON STEEL
13 PROLUNGA ESTERNA STEM EXTENSION	ACCIAIO AL CARBONIO CARBON STEEL
14 O-RING O-RING	VITON VITON
15 TAPPO CAP	ACCIAIO ASTM-A105 STEEL ASTM-A105
16 SPINA ELASTICA ELASTIC PIN	ACCIAIO AL CARBONIO CARBON STEEL
17 QUADRO MANOVRA OPERATION SQUARE	ACCIAIO AVP AVP STEEL
18 SPINA CILINDRICA CYLINDRICAL PIN	ACCIAIO INOX STAINLESS STEEL

**RIVESTIMENTO:** Vernice di colore nero RAL 9005 con spessore min 100µm.

**SURFACE PROTECTION:** black paint color RAL 9005 and minimum thickness of 100µm.

DN	Inch.	D	D2	D3	D4	d	n-ød	L	L2	H	H2	H3	Peso (kg) Weight
200	8	200	209	165	195	7.5	5-ø21	521	27	597	30	36	112