



## Valvole di ritegno a fuso ugello Venturi PN 10 ÷ 64

### Check valve "Venturi" (fused nozzle) PN 10 ÷ 64

Art. C 062: PN 10  
 Art. C 063: PN 16  
 Art. C 064: PN 25  
 Art. C 065: PN 40  
 Art. C 066: PN 64

#### Caratteristiche

- Chiusura rapida senza colpo d'ariete.
- Profilo idrodinamico con basse perdite di carico.
- Queste valvole si possono installare in posizione orizzontale, verticale ed obliqua.

#### Characteristics

- Quick closure without water hammering.
- Hydrostatic profile with low head loss.
- The valves could be installed in horizontal, vertical and battered position.

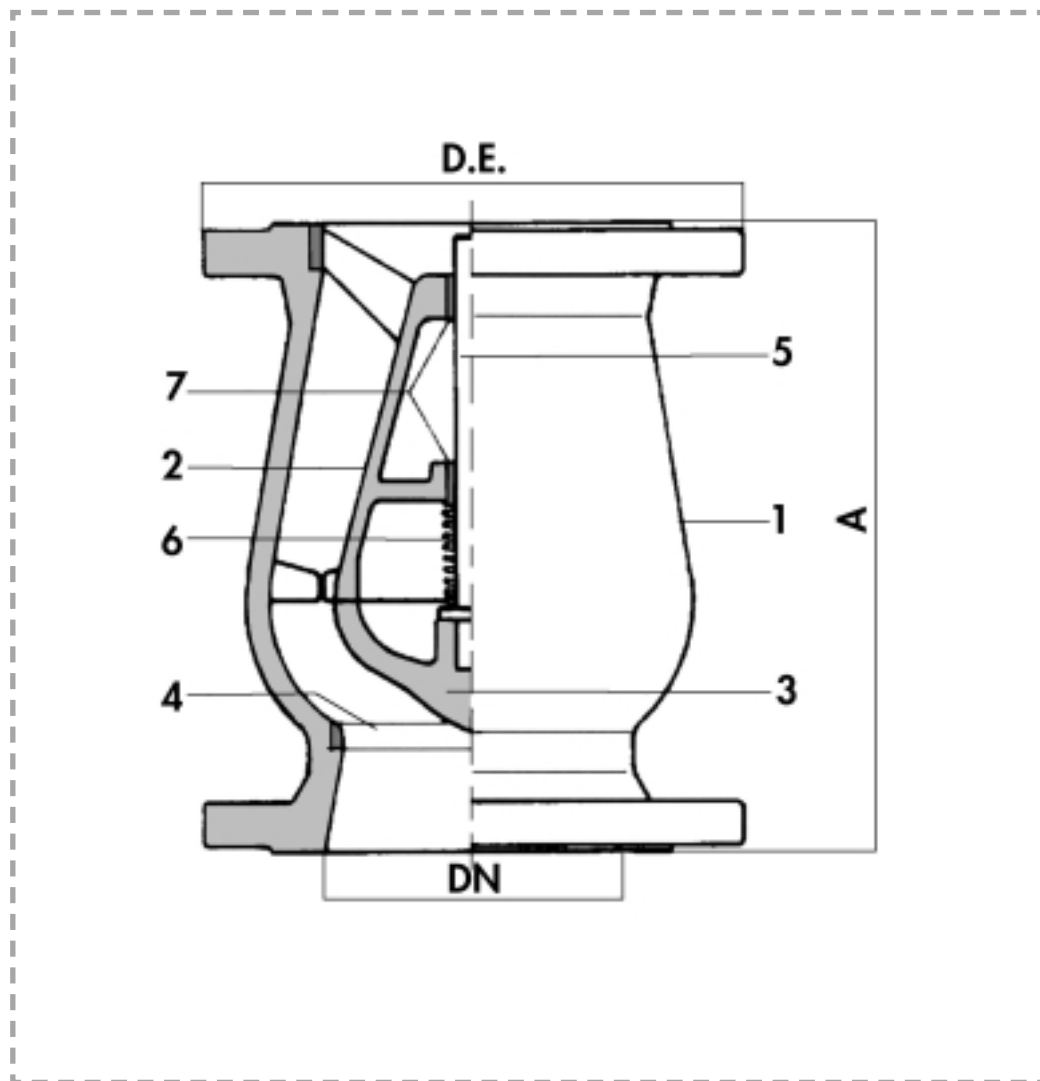

DN	PN	A	D.E.	Kg
40	10	120	150	7
40	16	120	150	7
40	25	120	150	7
40	40	120	150	7
40	64	120	170	12
50	10	120	165	7
50	16	120	165	7
50	25	120	165	7
50	40	120	165	7
50	64	120	180	12
65	10	150	185	11
65	16	150	185	11
65	25	150	185	11
65	40	150	185	11
65	64	150	205	16
80	10	180	200	17
80	16	180	200	17
80	25	180	200	17
80	40	180	200	17
80	64	180	215	21
100	10	240	220	23
100	16	240	220	23
100	25	240	235	27
100	40	240	235	27
100	64	240	250	34
125	10	300	250	33
125	16	300	250	33
125	25	300	270	40
125	40	300	270	40
125	64	300	295	53
150	10	350	285	45
150	16	350	285	45
150	25	350	300	54
150	40	350	300	54
150	64	350	345	75
200	10	400	340	75
200	16	400	340	75
200	25	400	360	100
200	40	400	375	106
200	64	400	415	125
250	10	450	395	115
250	16	450	405	115
250	25	450	425	130
300	10	500	445	135
300	16	500	460	145
300	25	500	485	170
350	10	600	505	210
350	16	600	520	220
400	10	700	565	300
400	16	700	580	315

No.	Materiali / Materials	Combinazione / Combination			
		PN 10/16	PN 25	PN 40	PN 64
1	Corpo Ghisa DN 40/50 / Cast Iron Body ND 40/50	GG 25	GG 25	GG 25	GS 400
1	Corpo Ghisa dal DN 65 al DN 400 / Cast Iron Body from ND 65 to ND 400	GG 25	GS 400	GS 400	GS 400
2	Ogiva DN 40/100 / Ogive ND 40/100	Ottone / Brass	Ottone	Ottone	Ottone
2	Ogiva DN 125/400 / Ogive ND 125/400	GG 25	GS 400	GS 400	GS 400
3	Otturatore DN 40/150 / Shutter ND 40/150	Completamente Inox 18/8 / Completely Stainless Steel 18/8			
3	Otturatore DN 200/400 / Body Seat ND 200/400	GS 400 con Sede Inox 18/8 / GS 400 and Seat Stainless Steel 18/8			
4	Seggio Corpo / Valve Stem	Anello Inox 18/8 / Stainless Steel 18/8			
5	Stelo / Stelo	Inox 18/8 / Stainless Steel 18/8			
6	Molla / Spring	Inox 18/8 / Stainless Steel 18/8			
7	Boccole per DN 200/400 / Bush ND 200/400	Bronzo / Bronze			